

### General Description

The WSD6040DN56 is the highest performance trench N-Ch MOSFET with extreme high cell density, which provide excellent  $R_{DS(on)}$  and gate charge for most of the synchronous buck converter applications.

The WSD6040DN56 meet the RoHS and Green Product requirement 100% EAS guaranteed with full function reliability approved.

### Features

- Lead Free and Green Devices Available (RoHS Compliant)
- 100% UIS + Rg Tested
- Reliable and Rugged
- Moisture Sensitivity Level MSL1

(per JED EC J-STD-020D)

### Absolute Maximum Ratings @ $T_A=25^{\circ}C$ unless otherwise noted

| Symbol            | Parameter                              |                    | Rating     | Units         |
|-------------------|--|--------------------|------------|---------------|
| $V_{DS}$          | Drain-Source Voltage                   |                    | 60         | V             |
| $V_{GS}$          | Gate-Source Voltage                    |                    | $\pm 20$   | V             |
| $I_D$             | Continuous Drain Current               | $T_C=25^{\circ}C$  | 36         | A             |
|                   |  | $T_C=100^{\circ}C$ | 22         |               |
| $I_D$             | Continuous Drain Current               | $T_A=25^{\circ}C$  | 8.4        | A             |
|                   |  | $T_A=100^{\circ}C$ | 6.8        |               |
| $I_{DM}^a$        | Pulsed Drain Current                   | $T_C=25^{\circ}C$  | 140        | A             |
| $P_D$             | Maximum Power Dissipation              | $T_C=25^{\circ}C$  | 37.8       | W             |
|                   |  | $T_C=100^{\circ}C$ | 15.1       |               |
| $P_D$             | Maximum Power Dissipation              | $T_A=25^{\circ}C$  | 2.08       | W             |
|                   |  | $T_A=70^{\circ}C$  | 1.33       |               |
| $I_{AS}^c$        | Avalanche Current, Single pulse        | $L=0.5mH$          | 16         | A             |
| $E_{AS}^c$        | Single Pulse Avalanche Energy          | $L=0.5mH$          | 64         | mJ            |
| $I_S$             | Diode Continuous Forward Current       | $T_C=25^{\circ}C$  | 18         | A             |
| $T_J$             | Maximum Junction Temperature           |                    | 150        | $^{\circ}C$   |
| $T_{STG}$         | Storage Temperature Range              |                    | -55 to 150 | $^{\circ}C$   |
| $R_{\theta JA}^b$ | Thermal Resistance Junction to ambient | Steady State       | 60         | $^{\circ}C/W$ |
| $R_{\theta JC}$   | Thermal Resistance-Junction to Case    | Steady State       | 3.3        | $^{\circ}C/W$ |

### Product Summary

| $BV_{DSS}$ | $R_{DS(on)}$ | $I_D$ |
|------------|--------------|-------|
| 60V        | 14m $\Omega$ | 36A   |

### Applications

- Secondary Side Synchronous Rectification
- DC-DC Converter
- Motor Control
- Load Switching

### DFN5X6-8L Pin Configuration

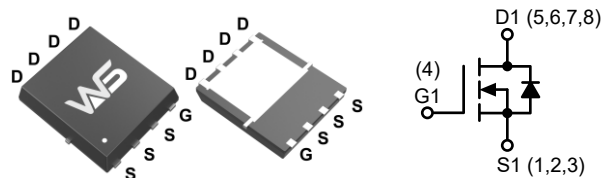

Note a: Pulse width limited by max. junction temperature.

Note b: Surface Mounted on 1in<sup>2</sup> pad area.

Note c: UIS tested and pulse width limited by maximum junction temperature 150°C (initial temperature T<sub>j</sub>=25°C).

**Electrical Characteristics @T<sub>A</sub>=25°C unless otherwise noted**

| Symbol  | Parameter                          | Conditions   | Min. | Typ. | Max. | Unit |
|---|------------------------------------|--|------|------|------|------|
| <b>Static</b>   |                                    |  |      |      |      |      |
| V <sub>(BR)DSS</sub>  | Drain-Source Breakdown Voltage     | V <sub>GS</sub> = 0V, I <sub>D</sub> = 250μA   | 60   |      |      | V    |
| I <sub>DSS</sub>  | Zero Gate Voltage Drain Current    | V <sub>DS</sub> = 48 V, V <sub>GS</sub> = 0V   |      |      | 1    | μA   |
|   |                                    | T <sub>J</sub> =85°C   |      |      | 30   |      |
| I <sub>GSS</sub>  | Gate Leakage Current               | V <sub>GS</sub> = ±20V, V <sub>DS</sub> = 0V   |      |      | ±100 | nA   |
| <b>On Characteristics</b>                                     |                                    |  |      |      |      |      |
| V <sub>GS(TH)</sub>   | Gate Threshold Voltage             | V <sub>GS</sub> = V <sub>DS</sub> , I <sub>D</sub> = 250μA   | 1    | 1.6  | 2.5  | V    |
| R <sub>DS(on)</sub> <sup>d</sup>                              | Drain-Source On-state Resistance   | V <sub>GS</sub> = 10V, I <sub>D</sub> = 25A  |      | 14   | 17.5 | mΩ   |
|   |                                    | V <sub>GS</sub> = 4.5V, I <sub>D</sub> = 20A   |      | 19   | 22   | mΩ   |
| <b>Switching</b>  |                                    |  |      |      |      |      |
| Q <sub>g</sub>  | Total Gate Charge                  | V <sub>DS</sub> =30V<br>V <sub>GS</sub> =10V<br>I <sub>D</sub> =25A  |      | 42   |      | nC   |
| Q <sub>gs</sub>   | Gate-Source Charge                 |  |      | 6.4  |      | nC   |
| Q <sub>gd</sub>   | Gate-Drain Charge                  |  |      | 9.6  |      | nC   |
| t <sub>d(on)</sub>  | Turn-on Delay Time                 | V <sub>GEN</sub> =10V<br>V <sub>DD</sub> =30V<br>I <sub>D</sub> =1A<br>R <sub>G</sub> =6Ω<br>R <sub>L</sub> =30Ω |      | 9    |      | ns   |
| t <sub>r</sub>  | Turn-on Rise Time                  |  |      | 17   |      | ns   |
| t <sub>d(off)</sub>   | Turn-off Delay Time                |  |      | 14   |      | ns   |
| t <sub>f</sub>  | Turn-off Fall Time                 |  |      | 58   |      | ns   |
| R <sub>g</sub>  | Gate resistance                    | V <sub>GS</sub> =0V, V <sub>DS</sub> =0V, f=1MHz   |      | 1.5  |      | Ω    |
| <b>Dynamic</b>  |                                    |  |      |      |      |      |
| C <sub>iss</sub>  | In Capacitance                     | V <sub>GS</sub> =0V<br>V <sub>DS</sub> =30V<br>f=1MHz  |      | 2100 |      | pF   |
| C <sub>oss</sub>  | Out Capacitance                    |  |      | 140  |      | pF   |
| C <sub>rss</sub>  | Reverse Transfer Capacitance       |  |      | 100  |      | pF   |
| <b>Drain-Source Diode Characteristics and Maximum Ratings</b> |                                    |  |      |      |      |      |
| I <sub>S</sub>  | Continuous Source Current          | V <sub>G</sub> =V <sub>D</sub> =0V, Force Current  |      |      | 18   | A    |
| I <sub>SM</sub>   | Pulsed Source Current <sup>3</sup> |  |      |      | 35   | A    |
| V <sub>SD</sub> <sup>d</sup>                                  | Diode Forward Voltage              | I <sub>SD</sub> = 20A, V <sub>GS</sub> =0V   |      | 0.8  | 1.3  | V    |
| t <sub>rr</sub>   | Reverse Recovery Time              | I <sub>SD</sub> =25A, dI <sub>SD</sub> /dt=100A/μs   |      | 27   |      | ns   |
| Q <sub>rr</sub>   | Reverse Recovery Charge            |  |      |      | 33   |      |

Note d: Pulse test ; pulse width ≤ 300μs, duty cycle ≤ 2%.

Note e: Guaranteed by design, not subject to production testing.

## Typical Operating Characteristics

**Power Dissipation**

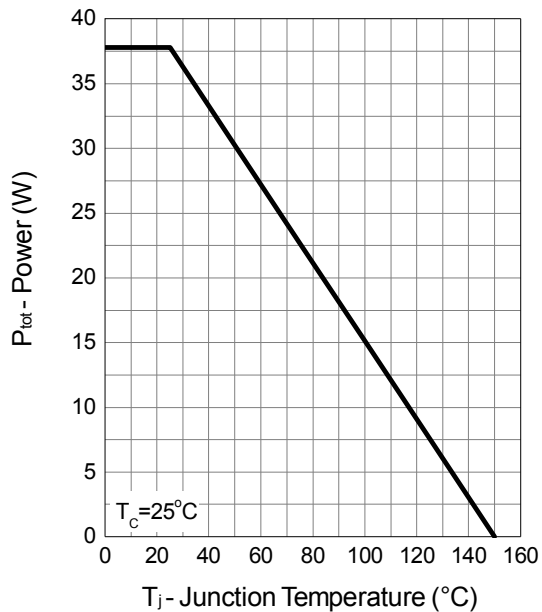

**Drain Current**

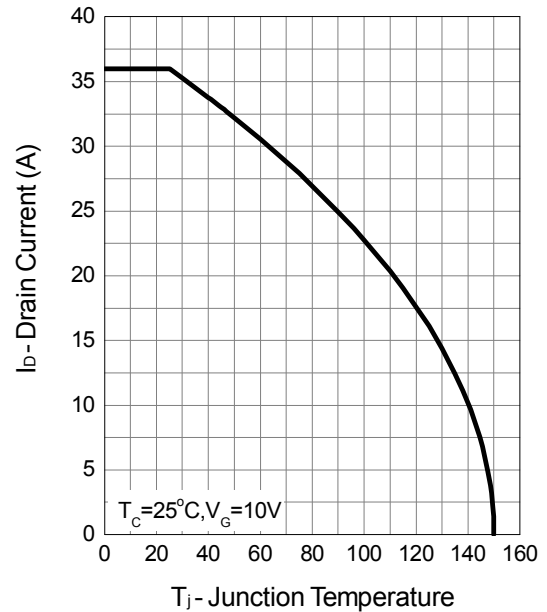

**Safe Operation Area**

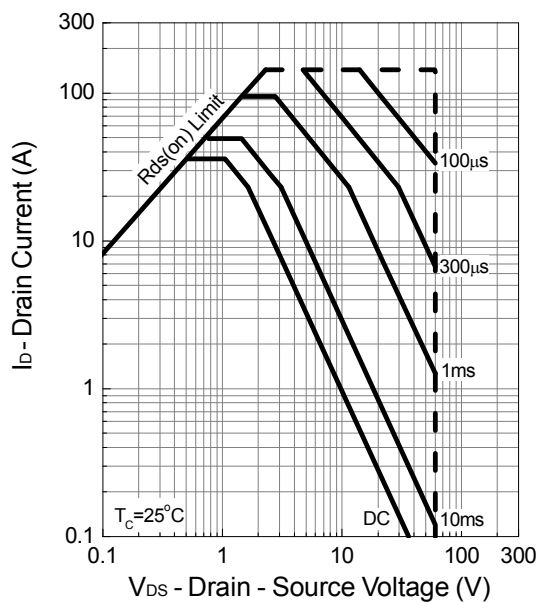

**Thermal Transient Impedance**

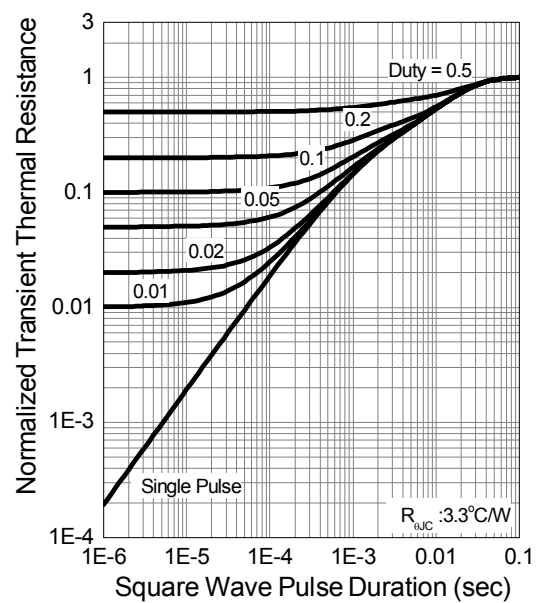

**Typical Operating Characteristics (Cont.)**

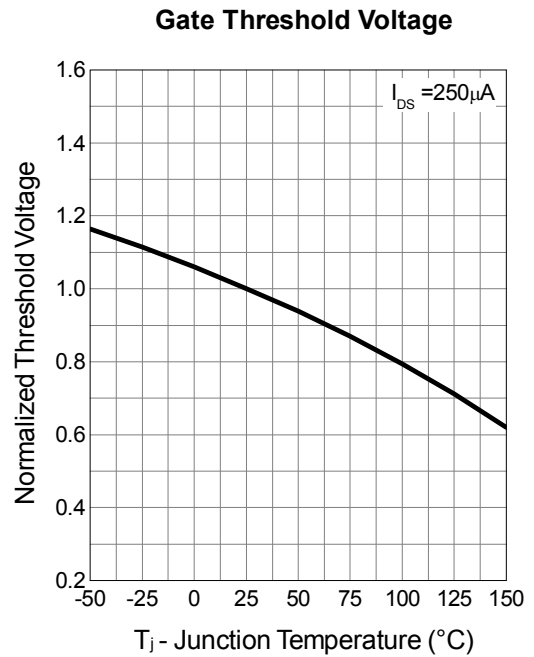
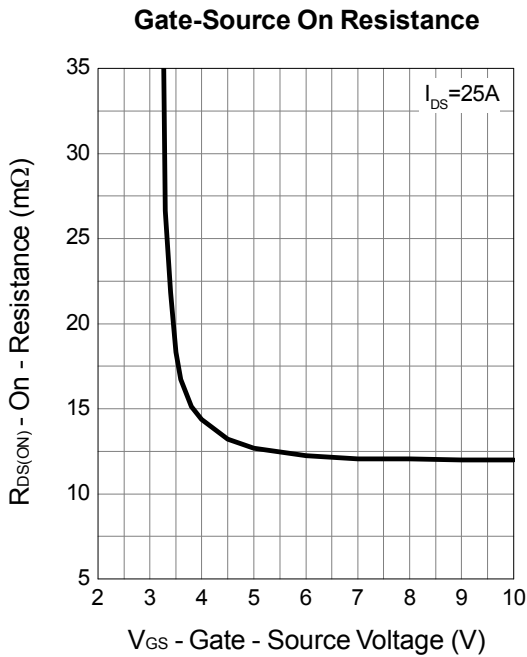
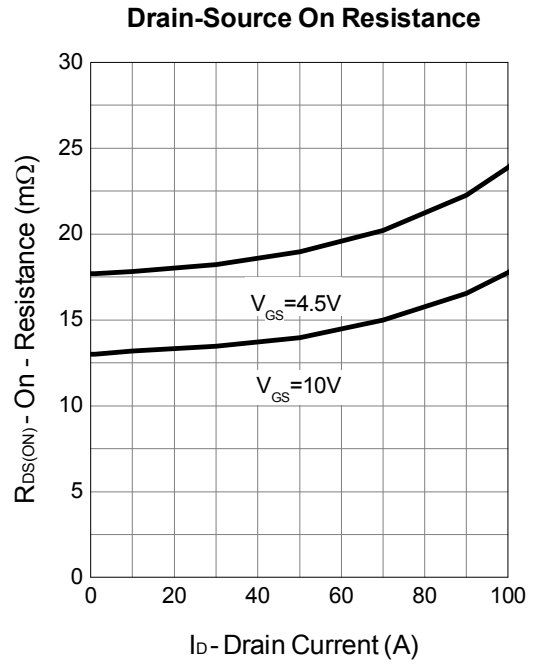
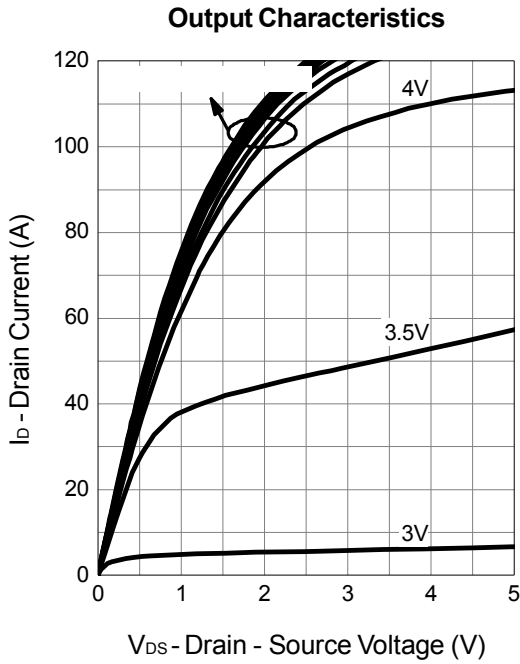

### Typical Operating Characteristics (Cont.)

**Drain-Source On Resistance**

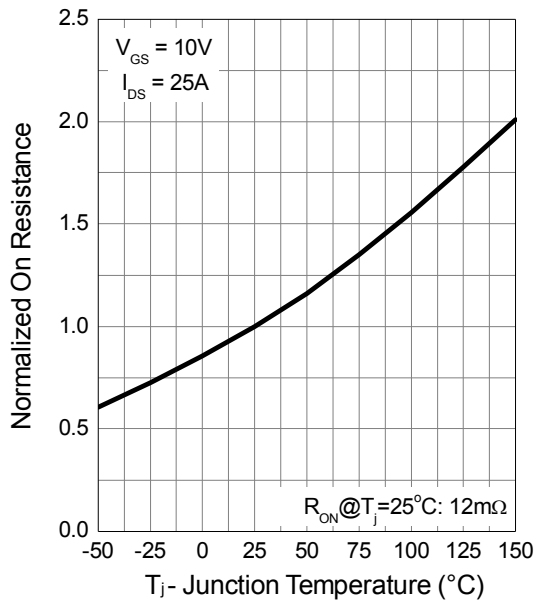

**Source-Drain Diode Forward**

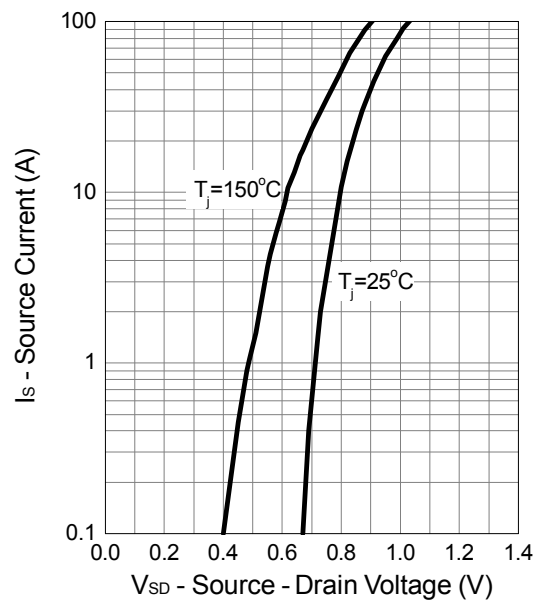

**Capacitance**

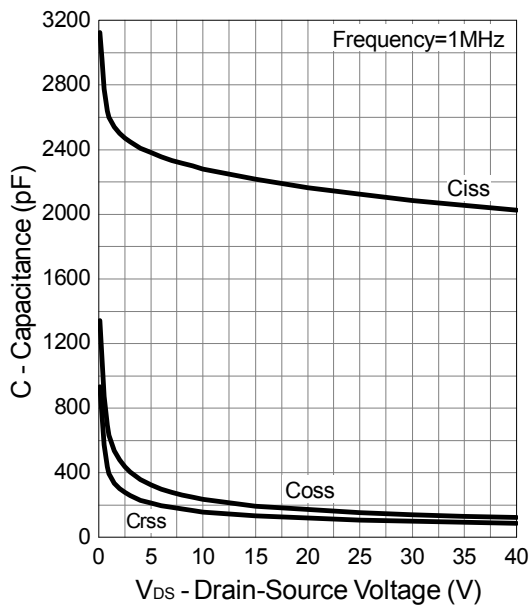

**Gate Charge**

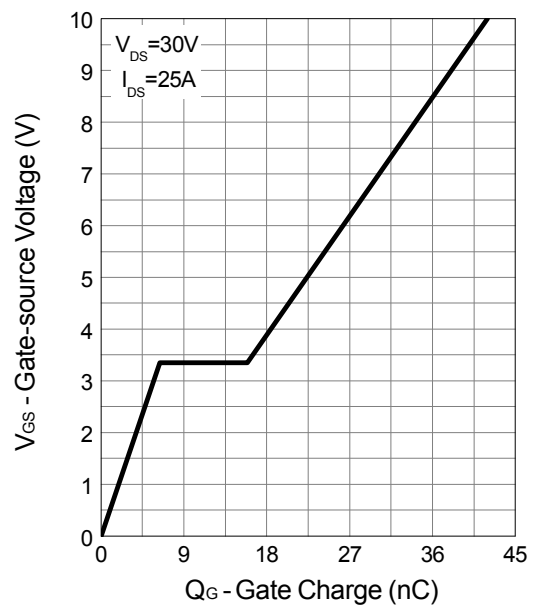

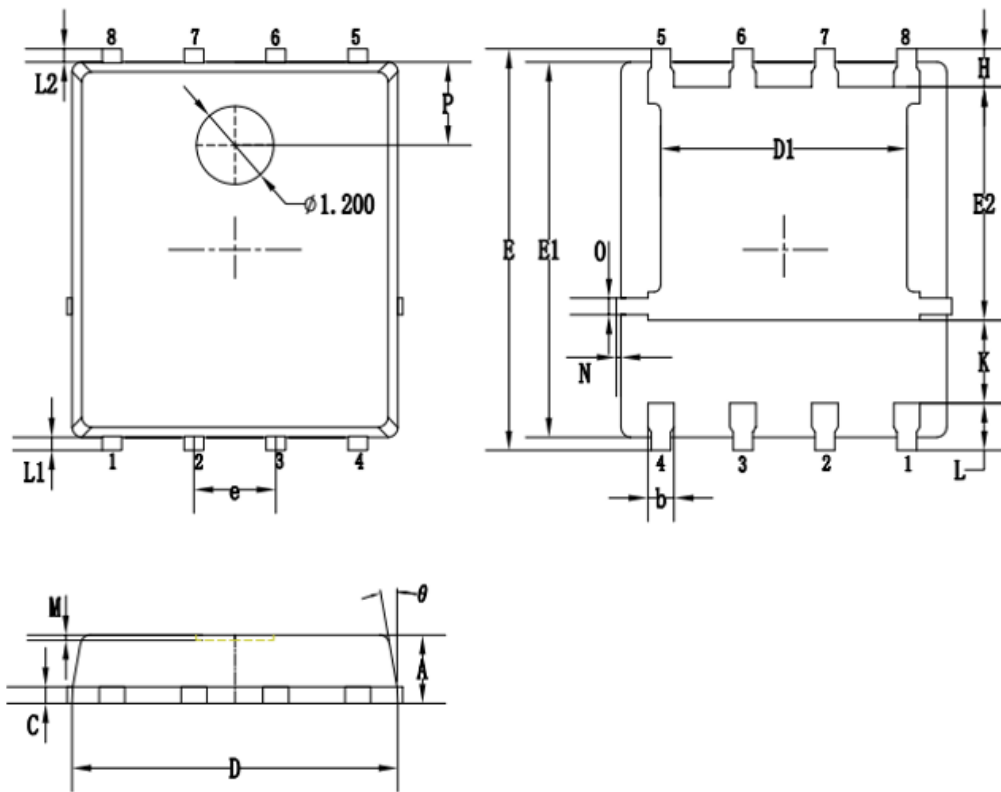
**Packaging information**

| SYMBOLS  | MILLIMETERS |      |      |
|----------|-------------|------|------|
|          | MIN.        | NOM. | MAX. |
| A        | 0.90        | 1.05 | 1.20 |
| b        | 0.35        | 0.40 | 0.50 |
| C        | 0.20        | 0.25 | 0.35 |
| D        | 4.90        | 5.05 | 5.20 |
| D1       | 3.72        | 3.82 | 3.92 |
| E        | 6.00        | 6.15 | 6.30 |
| E1       | 5.60        | 5.75 | 5.90 |
| E2       | 3.47        | 3.57 | 3.67 |
| e        | 1.27 BSC.   |      |      |
| H        | 0.48        | 0.58 | 0.68 |
| K        | 1.17        | 1.27 | 1.37 |
| L        | 0.64        | 0.74 | 0.84 |
| L1/L2    | 0.20 REF.   |      |      |
| $\theta$ | 8°          | 10°  | 12°  |
| M        | 0.08 REF.   |      |      |
| N        | 0           | -    | 0.15 |
| O        | 0.25 REF.   |      |      |
| P        | 1.28 REF.   |      |      |



## Attention

- 1, Any and all Winsok power products described or contained herein do not have specifications that can handle applications that require extremely high levels of reliability, such as life-support systems, aircraft's control systems, or other applications whose failure can be reasonably expected to result in serious physical and/or material damage. Consult with your Winsok power representative nearest you before using any Winsok power products described or contained herein in such applications.
- 2, Winsok power assumes no responsibility for equipment failures that result from using products at values that exceed, even momentarily, rated values (such as maximum ratings, operating condition ranges, or other parameters) listed in products specifications of any and all Winsok power products described or contained herein.
- 3, Specifications of any and all Winsok power products described or contained herein stipulate the performance, characteristics, and functions of the described products in the independent state, and are not guarantees of the performance, characteristics, and functions of the described products as mounted in the customer's products or equipment. To verify symptoms and states that cannot be evaluated in an independent device, the customer should always evaluate and test devices mounted in the customer's products or equipment.
- 4, Winsok power Semiconductor CO., LTD. strives to supply high-quality high-reliability products. However, any and all semiconductor products fail with some probability. It is possible that these probabilistic failures could give rise to accidents or events that could endanger human lives that could give rise to smoke or fire, or that could cause damage to other property. When designing equipment, adopt safety measures so that these kinds of accidents or events cannot occur. Such measures include but are not limited to protective circuits and error prevention circuits for safe design, redundant design, and structural design.
- 5, In the event that any or all Winsok power products (including technical data, services) described or contained herein are controlled under any of applicable local export control laws and regulations, such products must not be exported without obtaining the export license from the authorities concerned in accordance with the above law.
- 6, No part of this publication may be reproduced or transmitted in any form or by any means, electronic or mechanical, including photocopying and recording, or any information storage or retrieval system, or otherwise, without the prior written permission of Winsok power Semiconductor CO., LTD.
- 7, Information (including circuit diagrams and circuit parameters) herein is for example only; it is not guaranteed for volume production. Winsok power believes information herein is accurate and reliable, but no guarantees are made or implied regarding its use or any infringements of intellectual property rights or other rights of third parties.
- 8, Any and all information described or contained herein are subject to change without notice due to product/technology improvement, etc. When designing equipment, refer to the "Delivery Specification" for the Winsok power product that you intend to use.
- 9, this catalog provides information as of Sep. 2014. Specifications and information herein are subject to change without notice.